

8

7

6

5

4

3

2

1

*L9701, D9701, C9796, C9797, C9799, C9712 AND C9713 SHOULD ALL BE PLACED NEAR EACHOTHER.
 *PPVOUT_S0_LCDBKLT_SW SHOULD BE KEPT AS SHORT AS POSSIBLE.
 * LVDS_IC_BKLT_PWM SHOULD BE AWAY FROM BOOST CIRCUIT

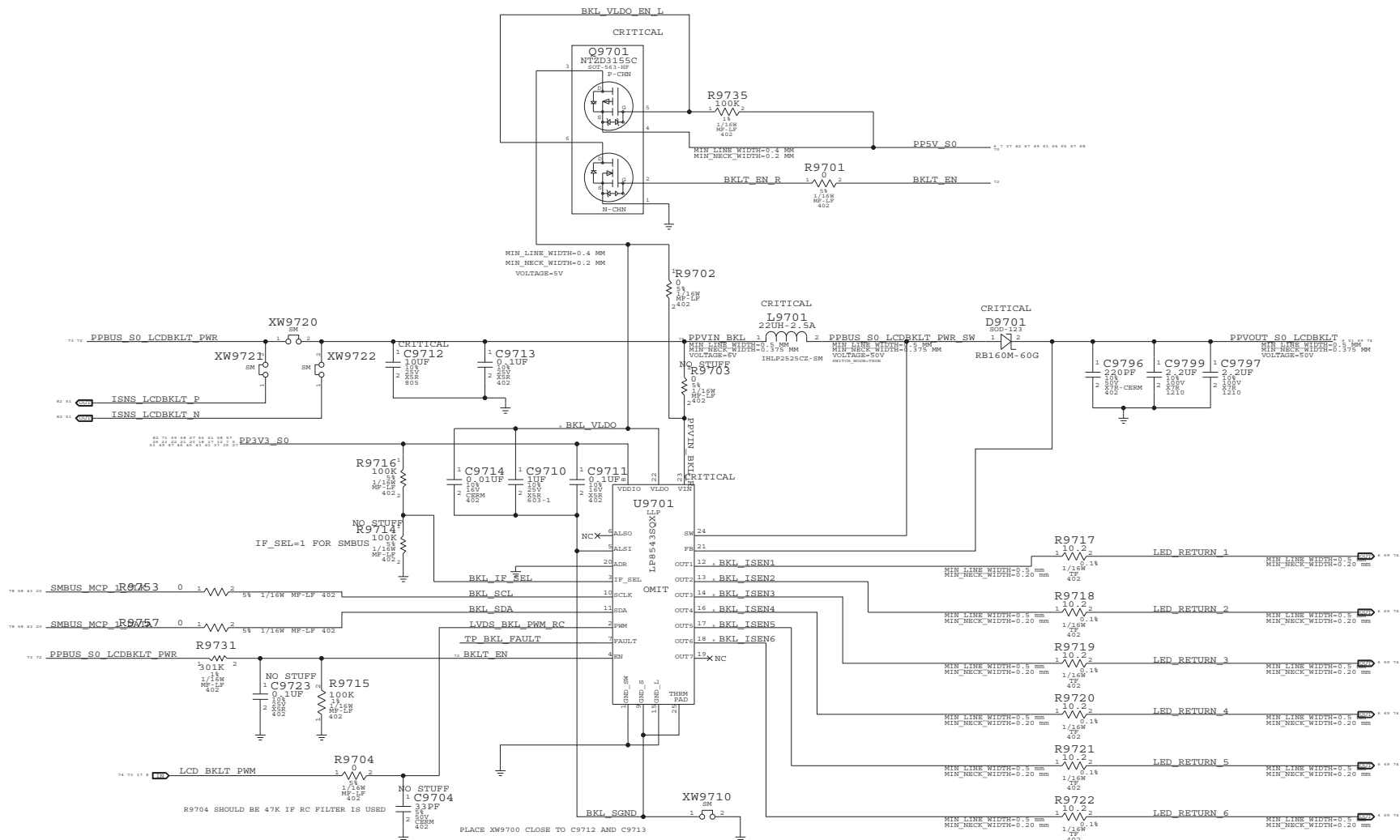

PART NUMBER	QTY	DESCRIPTION	REFERENCE DES	CRITICAL	BOM OPTION
353S2670	1	IC, LP8543, MHT LED BKLT, PROD	U9701	CRITICAL	

LCD BACKLIGHT DRIVER
 SYNC_MASTER=K19_MLB SYNC_DATE=02/10/2009
NOTICE OF PROPRIETARY PROPERTY
 THE INFORMATION CONTAINED HEREIN IS THE PROPRIETARY PROPERTY OF APPLE COMPUTER, INC. THE PROPRIETOR AGREES TO THE FOLLOWING:
 I TO MAINTAIN THE DOCUMENT IN CONFIDENCE
 II NOT TO REPRODUCE OR COPY IT
 III NOT TO REVEAL OR PUBLISH IN WHOLE OR PART

	SIZE	DRAWING NUMBER	REV.
	D	051-7903	A
SCALE	NONE	SHT	72 OF 83

8

7

6

5

4

3

2

1